



DKS 2000

fully automatic BLOCK packaging machine

As a convincing service provider we provide you with thorough advice and service – before and during the order processing and beyond this, with a reliable after sales service.

Design, function and handling answer to the state of the art in technology.

1 range of application

Fully automatic packaging machine for margarine, butter and other edible fats as well as similar products of various consistencies and sizes for further industrial processing.

The design and function of this block packaging machine is tailored to meet the highest degree of packaging quality and capacity.

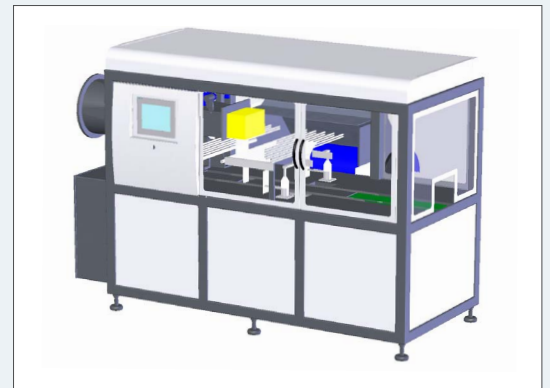

2 ,BOCK-TOUCH' system

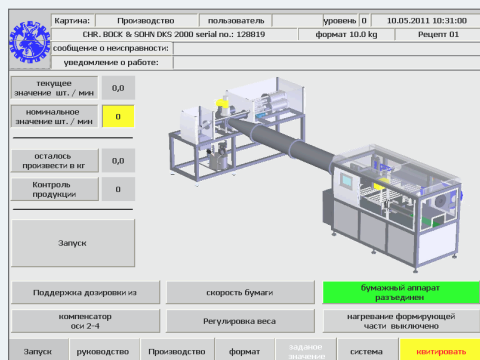

Exclusively for our machines

The ,BOCK-TOUCH' system controls your packaging plant via touch panel according to recipes, allowing reproducible results at any time.

Speed, temperatures, cycle times and other parameters relevant to the particular product in process are adapted automatically. The immediate fault analysis via online – teleservice provides perfect conditions for a maximum capacity production.

3 function

The feed in of the product is realized in a hygienically closed system by our volumetrically controlled double piston dosing unit. Through processing of the product in idleness, real resting phases are realized, guaranteeing a high plasticity unreached by continually running systems. The packaging material is automatically feed from the paper reel, cut true to dimension and then positioned accurately, ensuring continually high packaging quality. Furthermore the centering of blocks and folding of the side flaps with a diagonal movement of the folding units make the processing of particularly soft product possible. And finally the synchronization of operation sequences by rotary cams ensures the flow of production on the highest level of quality.

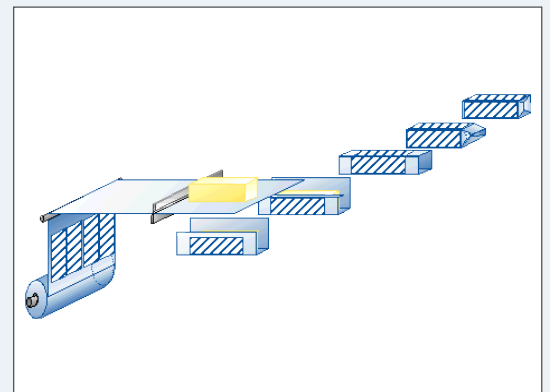



contact: CHR. BOCK & SOHN GmbH & Co. KG // An'n Slagboom 43-45 // 22848 Norderstedt // Germany
phone: +49 40 5284060 // fax: +49 40 52840622 // e-mail: mail@bockpack.com // www.bockpack.com

4 technical details

DKS 2000 fully automatic block packaging machine

range of size:	1-25 kg
max. performance:	13 t/h
packaging material:	min. 30 g/m ²
energy consumption:	7,5 kW in total
weight of machine:	4,6 t
operation:	line supervision (1 person)

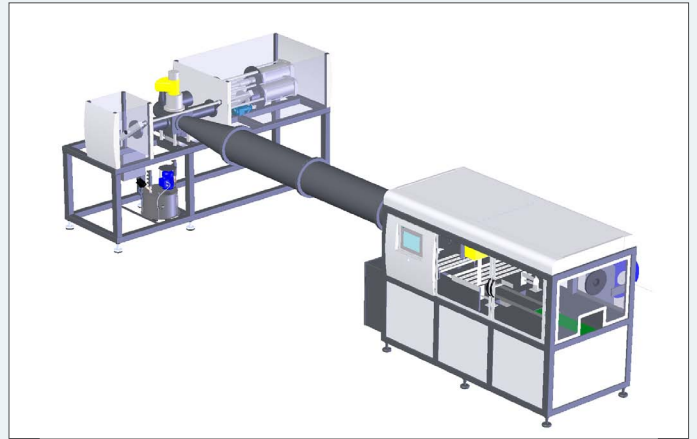

5 advantages



clear advantages ...

- robust and compact design
- layout and folding procedure, optimized for blocks
- intuitive operation via 12" color touch screen
- high output with highest weight precision
- excellent accessibility to all areas
- hygienically encapsulated packaging area
- well established technical concept
- manufactured completely from stainless steel
- meets highest hygienic standards
- 'Bock mood-line' optical signal
- teleservice

6 accessories

... and everything that goes with it

- pre-cutting of blocks
- block turning device
- printer
- check weigher
- antistatic device for wrapper
- hydraulic dosing assistance
- CIP-cleaning system
- resting tubes in various formats
- sieve and hole plate

Further accessories available



All given specifications are basic values and subject to change without prior notice.